

Series EASYMT & EASMT Solenoid Valves

IMPORTANT NOTES BEFORE INSTALLING

OPERATION

All Series "EASYMT" and "EASMT" PTFE Bellows solenoid valves are direct acting, 2-way, and normally closed valves. When their solenoid coils are de-energized the valves are closed, and open when the coils are energized. Valves with 24 watt coils can be energized continuously.

FAIL-DRY® DESIGN

All series "EASYMT" and "EASMT" valves utilize the PLAST-O-MATIC patented FAIL-DRY® safety design which features a vented chamber separating two (2) sealed sections of the valve body. This concept is extremely important for solenoid valves used in the chemical processing industry as it protects the metal operating components from corrosion that could cause valve failure and offers a warning of valve leakage before a failure occurs.

INSTALLATION

Please check the nameplate for correct part number, pressure ratings, and voltage. Also check the flow label located on the side of the valve body to insure proper flow direction. If flow label is missing, the inlet can be distinguished from the outlet port. The outlet is always deeper than the inlet.

PLAST-O-MATIC solenoid valves operated by 24 watt coils can be mounted horizontally or vertically; however, vertical mounting (coil up) is preferred since it results in longer cycle life.

Valves should **NEVER** be mounted with the coils on the bottom. When installing these valves in a piping system they should only be connected to plastic pipe or plastic fittings. All male threads should be wrapped with PTFE tape or other acceptable pipe sealant. To prevent stringing of the PTFE tape into the inner workings of the valves, be sure to keep the tape at least one full thread from the end of the pipe.

Whenever PTFE tape or other pipe sealants are used there is a tendency to over-torque because of the reduced friction. Therefore, connections should only be made hand-tight followed by one quarter turn more. Greater forces tend to stretch or distort the plastic bodies which could lead to future ruptures. Strap wrenches may be used for assembly. Metal pipe wrenches should **NEVER** be used as they can deeply scratch the plastic surfaces causing additional stresses.

Wiring should comply with all applicable electrical codes, local or otherwise. Care should be taken to insure that the solenoid coil leads cannot be pulled from the coil. If flexible conduit is not used to connect to the solenoid housing the supply conduit must be properly aligned and supported to prevent stressing the solenoid assembly. See Wiring Diagram.

VALVE PRESSURE RATINGS

These PLAST-O-MATIC solenoid valves are direct acting and do not require minimum operating pressure differentials, but the maximum inlet and back pressure ratings must not be exceeded. If the maximum inlet pressures are exceeded the valves will not open and the coil can burn out.

Back pressure can result in two (2) ways. First, from a separate pressure source in the downstream piping. And second, from the flow of liquid through the downstream piping. If the back pressure rating is exceeded in the first situation the valve will open and a reverse flow will take place if there is a lesser inlet pressure. In the second situation the valve will not close and flow will continue. When back pressures are caused by the liquid flow it naturally follows that any restriction in the downstream piping will cause even higher back pressures. This is especially true with spray nozzles.

The following chart is to provide overall guidelines on various thermoplastics relative to their pressure and temperature relationships. The information should be used to determine limitations of the various materials rather than selection of a specific valve since each individual valve model has its own pressure ratings. Refer to specifications table in the product catalog.

MATERIALS TEMPERATURE vs. PRESSURE								
MAT'L	MAX. TEMP	MAXIMUM INLET PRESSURES AND TEMPERATURES						
		75°F (24°C)	110°F (43°C)	140°F (60°C)	180°F (82°C)	220°F (105°C)	240°F (116°C)	284°F (140°C)
PVC	140°F (60°C)	140 9,6	100 6,8	40 2,7	N.R.	N.R.	N.R.	N.R.
CPVC	180°F (82°C)	140 9,6	100 6,8	80 5,4	40 2,7	N.R.	N.R.	N.R.
GPP**	220°F (105°C)	140 9,6	120 8,2	100 6,8	80 5,4	40 2,7	N.R.	N.R.
PVDF	284°F (140°C)	140 9,6	130 8,8	120 8,2	100 6,8	60 4,1	30 2,0	10 0,7

N.R. = Not Recommended

GPP** = Glass-Filled Polypropylene

MAINTENANCE

The major causes of solenoid valve failure are usually either chemical incompatibility, damage from water hammer or foreign matter in the valve. Water hammer may be minimized by adhering to a safe piping velocity of 5 feet per second. Commonly encountered foreign matter includes pipe sealants, mineral and salt deposits, and other solids.

Before disassembling a valve for examination or cleaning make sure all electrical power and fluid line pressure are turned off. It should be noted that even after a pump is shut down to eliminate fluid line pressure there may still be pressure trapped in the piping system. One example of this would be head pressure located in a vertical run of pipe. If this situation is possible, extreme caution should be exercised when removing the top housing from the valve body. It would be advisable to place a clear plastic shield over the valve during disassembly to avoid injuring a worker. **CAUTION:** Avoid breathing dangerous vapors and avoid skin contact with chemicals.

Whenever disassembling a valve it is wise to carefully inspect all of the parts to insure proper operation when it is reassembled. It is also a good idea to have a spare seal kit on hand.

When removing foreign matter or deposits on the valve seat or other internal parts, care should be taken not to scratch or nick the parts being cleaned.

After reassembly, operation should be checked by energizing the solenoid coil. If the valve is operating properly, a sharp metallic click will usually be heard when the valve's coil is energized.

FAIL-DRY® is a registered trademark of Plast-O-Matic Valves, Inc.

SERIES EASYMT AND SERIES EASMT

Seal Kit Replacement

REFER TO PARTS DRAWING

- Before disassembly, relieve pressure and drain fluid from the valve and piping to be opened. Take proper precautions to protect people and equipment from any residual liquid. Remove cap nut and coil assembly.
- Disassemble the valve in a clean environment. Prevent any dirt, grit, or fiber from getting onto the sealing surfaces or into the moving parts. Do not scratch or damage plastic parts. Remove four (4) fasteners.
- A non-scratching probe such as an orangewood stick or ball-end dental pick (burnisher) should be used to remove and install O-rings.
- Pipe wrenches and vises are not recommended for plastic valves.
- Refer to the valve instruction sheet for installation to piping.
- Align the FAIL-DRY[®] port to the inlet side, or as convenient.
- Replace old seal kit with new. Reassemble; re-install fasteners to 25 in-lbf/2.82 N·m.

NEED HELP? Call 1-973-256-3000
for Tech Support.

(Have valve model number and voltage ready)

WIRING DIAGRAMS

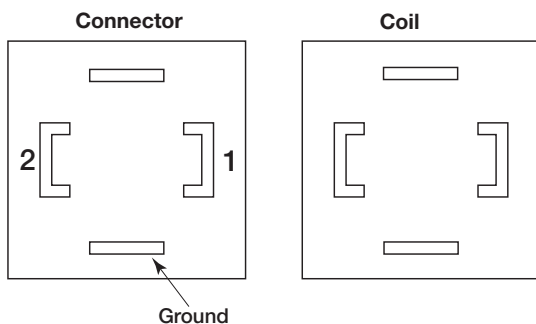

Terminals 1 & 2 are not polarity sensitive.
 Connector can be placed, wire facing up or down.

Z-Cool-DIN 894524 VAC
Z-Cool-DIN 894624 VDC
Z-Cool-DIN 8943120 VAC
Z-Cool-Din 8944240 VAC

For AC voltages, 50 or 60 Hz is acceptable.

PTFE BELLOWS ASSEMBLY

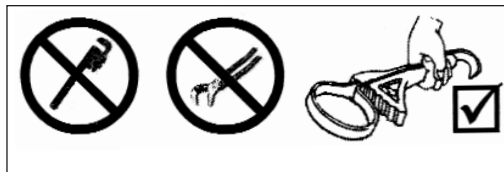
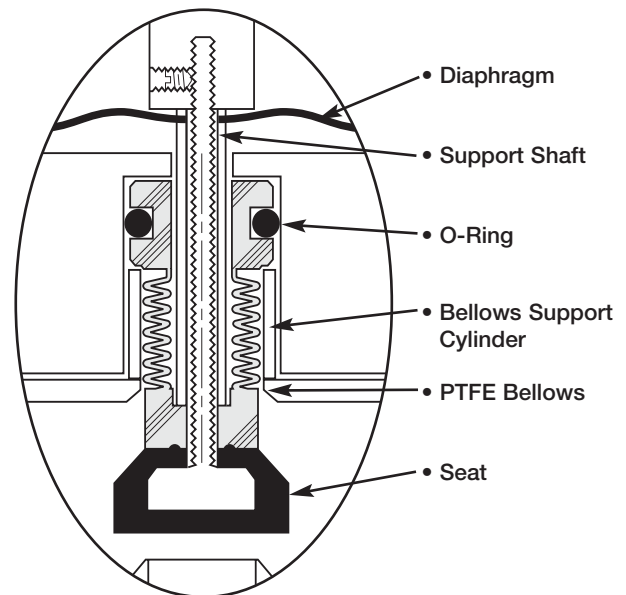

TYPE W24 SOLENOID COIL

IMPORTANT NOTES BEFORE INSTALLING

Type W24 (24 Watt) solenoid coils, rated IP65 (weather proof and suitable for outdoor use) are designed to be used with Plast-O-Matic solenoid valves. The solenoid consists of the coil, plunger (AKA core), core tube housing and a few other parts. When energized, the solenoid creates a magnetic field that causes the core to move thus opening or closing the valve depending on the design of the valve. You, the end user, must apply the correct voltage for your particular valve/solenoid. This voltage (and part number) is imprinted on the coil.

IMPORTANT: these coils MUST be operated with the connector that was supplied by the factory, or the correct replacement connector if required. If used with the wrong connector, the valve will not operate. The coil, voltage and part numbers of the coil and connector are provided below. All connectors are designed for 1/2" NPT conduit connection. These connectors meet DIN 43650/ISO 4400 form A.

The reason the correct connector must be used is because the connector performs a special function. First it rectifies the voltage, and second it allows full voltage to the coil for a short time (less than 1 second), and then reduces the voltage to a lower holding value. Rectified voltage has several advantages:

1. It is much quieter than AC voltage, which tends to hum and occasionally buzz.
2. The coil can be on/off cycled without increasing the heating like AC coils will.
3. In case the coil is energized without being mounted on the valve, no harm is done.

The reason for dropping the voltage after the valve opens (or closes in the case of a normally open valve), is because once the valve has switched to its energized position, it no longer needs full voltage. Most of that energy is wasted in heat and the coil gets very hot. With this special connector the coil uses much less energy, and runs very cool even if energized indefinitely. If the solenoid is de-energized and energized again, the connector will perform the same sequence thus assuring the valve will always operate as required.

As a result of the connector function described above, the coil draws 24 watts for less than one second and as it remains energized it will draw less than 4 watts, saving energy, and running much cooler.

COIL PART NUMBER	INPUT VOLTAGE	CONNECTOR PART NUMBER
8826W-240VAC	240 VAC	Z-COOL-DIN8944
8825W-24VAC	24 VAC	Z-COOL-DIN8945
8824W-120VAC	120 VAC	Z-COOL-DIN8943
8827W-24VDC	24 VDC	Z-COOL-DIN8946

SPECIFICATIONS

Insulation class	H
Watts (maximum)	24 (watts drop to approx. 4 watts after initially energized)
Duty Cycle	100% (may be energized indefinitely, or rapid on/off cycling is acceptable)
Max. Ambient temp	50° C (122° F)
Voltage tolerance	10% above or below rated voltage. **See note below
Current (amps)	See table below.
Enclosure Rating	IP65

****Note at 10% above rated voltage the coil will run a little warmer**

COIL PART NUMBER	MAXIMUM CURRENT (LESS THAN 1 SECOND)	HOLDING CURRENT
8826W-240VAC	0.15	0.03
8825W-24VAC	0.85	0.22
8824W-120VAC	0.22	0.06
8827W-24VDC	1.1	0.3

INSTALLATION CAUTION: Electrical wiring shall be performed by qualified persons in accordance with all national and local electrical codes. Three wire (single phase, grounded) is required. A 1/2" NPT threaded connection and all gaskets supplied must be used to maintain IP65 weather tight rating.

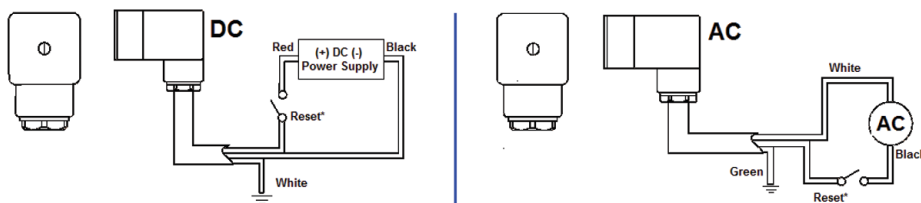

SERIES EASMT

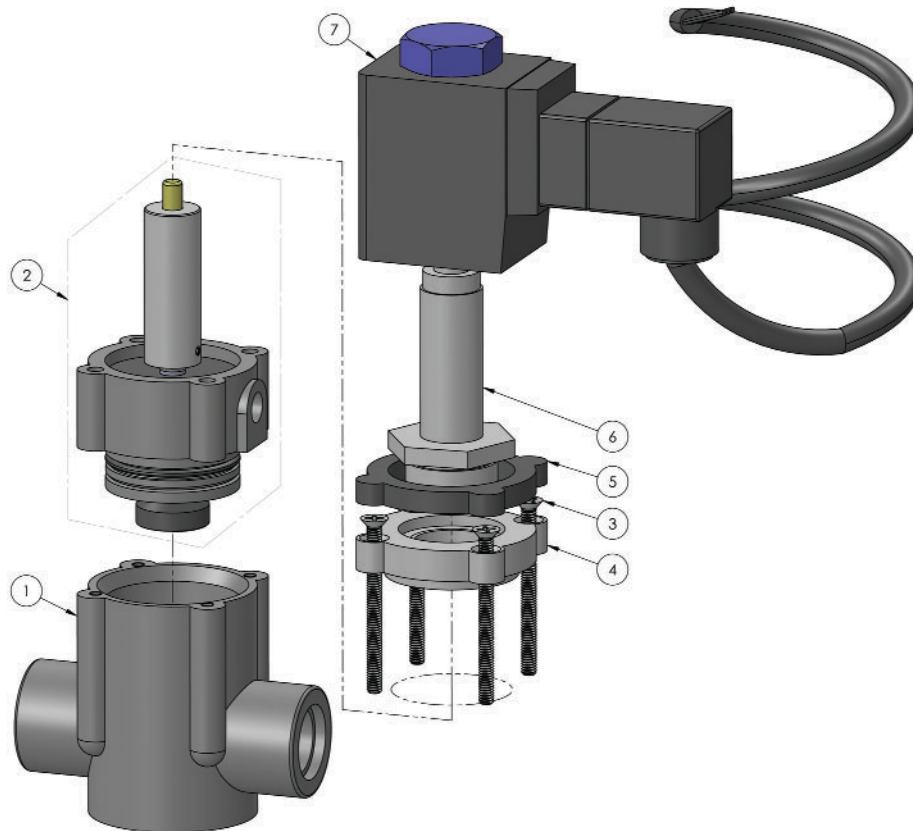

ITEM NO.	DESCRIPTION	QTY.
1	BODY / NPT	1
2	SEAL KIT FOR EASMT	1
3	SS MACHINE SCREW FLAT 8-32 X 2"	4
4	HALAR MOUNT	1
5	CLOSED CELL EPDM GASKET	1
6	ARMATURE TUBE	1
7	COIL ASSEMBLY	1