

NEW
24-WATT COIL
 Continuous Duty
 Cool-To-Touch
**USES 75%
 LESS ENERGY**
 Than Previous Version

PTFE Bellows Solenoid Valve Prevents Fugitive Emission Leaks One Valve Handles All Type Solutions!

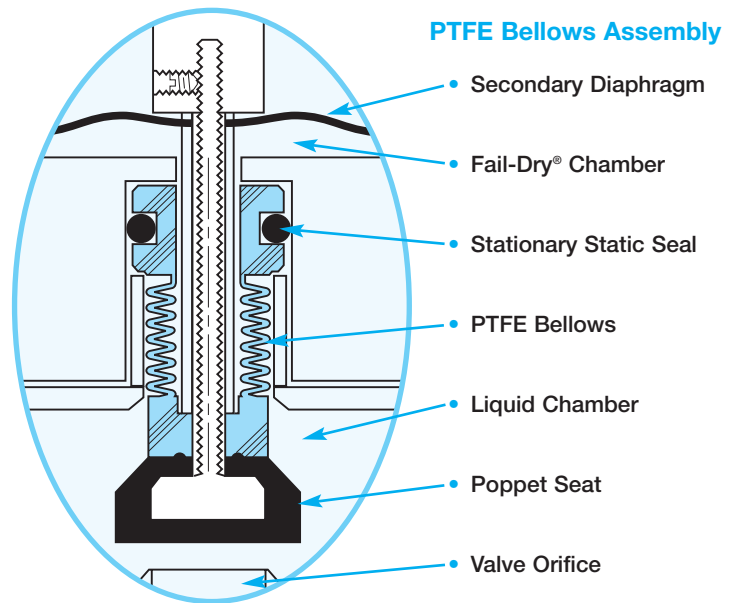

Technological and engineering breakthrough...

A single thermoplastic valve, designed for severe service applications with virtually every type of liquid. For pressure, drain or vacuum service. Sizes: 1/4" to 1".

OUTSTANDING FEATURES

- **Unique Design:** PTFE Bellows barrier-type dynamic seal prevents leaking of fugitive emissions to the atmosphere.
- **Versatility:** For use with virtually every type solution, including acids, caustics, solvents, chlorine solutions and ultra-pure liquids.
- **Superior Performance:** Over 2 million cycles in laboratory conditions.
- **Dependability and Safety:** Patented Fail Dry® design provides visual warning if seal malfunctions. Avoids costly shutdown, as valve continues to function.
- **New W24 Solenoid Coil** with Z-Cool DIN Connector uses a fraction of the energy required by traditional coils. Optional R24 coil available.
- **Rated Continuous Duty** with maximum ambient temperature of 122°F/50°C.
- **Coil Connector Light:** Indicates when valve is energized (open). Standard on W24 coil.
- **Corrosion Resistant:** Rugged thermoplastic construction is resistant to both internal and atmospheric corrosion. no metal parts in wetted areas. Available in PVC, CPVC, Polypropylene and PVDF.
- **Exacting Quality:** All valves individually inspected and 100% tested to insure reliable operation.



Leadership Though Innovative Products, Engineering Excellence and Dependable Performance!

PRESSURE RATING CONSIDERATIONS FOR ALL MODELS

Inlet Pressure: Inlet pressure ratings in the tables below are at full rated line voltage for alternating current (A.C.) or direct current (D.C.) If rated pressures are exceeded the valve will not open.

Back Pressure: An important consideration in solenoid valve selection is the back pressure rating shown in the specifications table below. Back pressure is caused by the resistance to flow in the piping downstream of the valve. Nozzles, goosenecks, fittings, tubing, or reduced outlet piping all create restrictions that raise the back pressure. Excessive back pressure will cause a valve to remain open

when power is shut off. A second type of back pressure is that which comes from a separate pressure source downstream of the valve. This could be head pressure from a storage tank or pressure from another pump, etc. Plast-O-Matic solenoid valves will not stay closed if the back pressure is higher than the inlet pressure. *Back pressure or downstream pressure is the most common cause of solenoid valve problems during system start-up. Therefore, sources of potential backpressure must be considered during the planning stages of a piping system.*

SPECIFICATIONS AND MODEL NUMBERS SERIES EASYMT AND EASMT										
Pipe Size	Orifice Size In. mm		Watts	Cv	AC or DC COILS				Molded Body Viton® FKM Seals Model Numbers	
					Max. Inlet Pressure		Max. Back Pressure			
					PSI	BARS	PSI	BARS		
1/4	.375	9,5	24	1.2	140	9,5	38	2,6	EASYMT2V12W24	
1/2	.375	9,5	24	1.2	140	9,5	38	2,6	EASYMT4V12W24	
1/2	.375	9,5	24	2.0	125	8,5	18	1,2	EASMT4V12W24	
3/4	.470	12,7	24	3.2	58	3,9	17	1,1	EASMT5V16W24	
1	.656	16,7	24	4.2	15	1,0	12	0,8	EASMT6V22W24	
1**	.452	11,5	24	3.2	25	1,7	12	0,8	EASMT6V14W24	

1. The Model Numbers listed show Viton FKM seals. For EPDM seals (optional) change "V" to "EP". Prices are the same for all seals mentioned.
2. Model Numbers are shown with "W24" (IP65 style coil). For R24 coil, change "W24" suffix to "R24."
3. All Model Numbers must be completed with body material at the end as follows: For Molded Bodies: PVC with "PV", CPVC with "CP", glass filled Polypropylene with "PP" and PVDF (Kynar) with "PF".
4. Valves in above chart are rated for full vacuum of 30" of mercury (Hg) except for 1" sizes which are rated for 15" of mercury (Hg) maximum.

5. The 24 watt coils are rated continuous duty. See Coil Specifications on page 4 for complete details.
6. W24 includes 18" lead; connector must not be separated from coil. R24 includes DIN connector only; no leads.

**This is an optional version of the 1" valve, where the design has been modified to allow higher inlet pressure at the sacrifice of lower Cv.

PRESSURE RATING & FLOW RATE CONSIDERATION

The pressure ratings shown in the table above are maximum values. The valve will open at the maximum listed inlet pressure and it will close at the maximum listed back pressure. The valve may not operate properly, however, when the maximum inlet and back pressure values are experienced at the same time. The governing parameter is velocity in feet per second (ft/sec) through the valve. Velocity is determined by pipe size and flow rate. To determine if your application exceeds the velocity tolerances for this valve, refer to the chart at right.

If your flow rate (in Gallons per Minute or Liters per Minute) is below 5 ft/sec column for your pipe size, the velocity is within plastic piping industry standards and the valve will function properly.

If your flow rate indicates a velocity above the accepted standard of 5 ft/sec but less than 10 ft/sec, Plast-O-Matic

FLOW RATE AND EQUIVALENT VELOCITY				
Valve Pipe Size NPT / BSP	Flow Rate At 5 feet per second velocity		Flow Rate At 10 ft. per second velocity	
0.50" 1/2 in.	3.4 G.P.M.	12.9 L.P.M.	6.8 G.P.M.	25.7 L.P.M.
0.75" 3/4 in.	6.4 G.P.M.	24.2 L.P.M.	12.8 G.P.M.	48.5 L.P.M.
1.00" 1 in.	10.8 G.P.M.	40.9 L.P.M.	21.6 G.P.M.	81.8 L.P.M.

does not guarantee proper operation. The valve may still function, but if it emits a chattering sound, discontinue use. At flow above 5 ft/sec you must consider water hammer in the system design.

If your flow rate is higher than that listed in the 10 ft/sec column for your pipe, this valve must not be used in your application.

TEMPERATURE REFERENCE MATERIAL

The following chart is to provide overall guidelines on various thermoplastics relative to their pressure and temperature relationships. The information should be used to determine limitations of the various materials rather than

selection of a specific valve since each individual valve model has its own pressure ratings. See specifications table above.

MATERIAL TEMPERATURE vs. PRESSURE															
Material	Maximum Temperature Rating	MAXIMUM INLET PRESSURE AND TEMPERATURE													
		75°F PSI	24°C BARS	110°F PSI	43°C BARS	140°F PSI	60°C BARS	180°F PSI	82°C BARS	220°F PSI	105°C BARS	240°F PSI	116°C BARS	284°F PSI	140°C BARS
PVC	140°F (60°C)	140	9,6	100	6,8	40	2,7	N.R.	N.R.	N.R.	N.R.	N.R.	N.R.	N.R.	N.R.
CPVC	180°F (82°C)	140	9,6	100	6,8	80	5,4	40	2,7	N.R.	N.R.	N.R.	N.R.	N.R.	N.R.
PP**	220°F (105°C)	140	9,6	120	8,2	100	6,8	80	5,4	40	2,7	N.R.	N.R.	N.R.	N.R.
PVDF	284°F (140°C)	140	9,6	130	8,8	120	8,2	100	6,8	60	4,1	30	2,0	10	0,7

**Glass-filled Polypropylene

N.R. – Not Recommended

PTFE BELLOWS SOLENOID VALVES

APPLICATION • DESIGN • OPERATION

Application: PTFE bellows solenoid valves automatically shutoff flow of highly corrosive or ultra-pure liquids including acids, caustics, solvents and chlorine solutions. They can handle pressure, drain or vacuum applications and do not require pressure to aid in opening the valve.

Design and Operation: Valves are spring return normally-closed and direct-acting with a simple push-pull plunger design. There is no minimum pressure required for operation. The PTFE bellows shaft seal eliminates the need for an elastomer seal which can weaken as a result of chemical attack. The PTFE bellows assures non-sticking operation and exceptionally long cycle life; over 2 million cycles. The bellows design also allows a stock valve to be used for vacuum or pressure. The poppet seat ensures bubble-tight shutoff.

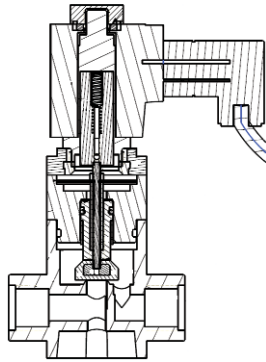

Fail Dry® Safety Design: Unique protection is provided by Plast-O-Matic's patented Fail-Dry design which incorporates a vented chamber and a secondary back-up diaphragm to handle any unusual seal failure occurrence. The Fail-Dry safety feature provides visual warning of seal malfunction and permits the valve to continue operating until a scheduled maintenance can be planned thereby avoiding a costly shutdown.

Vacuum Information: PTFE Bellows solenoid valves are rated for full vacuum of 30" of mercury except for 1" sizes, which are rated for a vacuum of 15" of mercury.

CAUTION: Not recommended for use with pressurized dry chlorine; vacuum to 30 Hg only. Please specify "chlorine-vacuum" when ordering.

MATERIALS OF CONSTRUCTION

Bodies: PTFE bellows solenoid valve bodies are available in a broad range of materials. Series EASYMT and EASMT molded bodies are available in Geon® PVC, Corzan® CPVC, glass-filled polypropylene and Kynar® PVDF. Some components in glass-filled polypropylene EASYMT and EASMT are made of Kynar PVDF.

Seals: Standard seal material for all molded and machined Bellows solenoid valves is a special treated Viton® FKM. With this material, a single valve can handle virtually all types of solutions including acids, caustics, solvents, chlorine solutions and ultra-pure liquids. Multi-purpose capability results in significant convenience and cost efficiency, since only one valve is needed for inventory.

W24 COIL

Standard production for PTFE bellows solenoid valves includes the new W24 (24 watt) coil. This molded unit is equipped with a Z-Cool DIN lighted connector having 18" leads for convenient connection. Coil assembly is IP65 rated. The W24 solenoid coil and Z-Cool DIN connector MUST be used together. The W24 will not function properly without the Z-Cool DIN connector. Warranty is voided if W24 used without Z-Cool.

CONNECTOR LIGHT

The bellows solenoid valves W24 coil includes a unique connector indicator light. With this standard feature, the connector lights up to show when the solenoid is energized.

For complete coil information, see page 4.

OPTIONAL R24 COIL

Optional coil for PTFE bellows solenoid valves is the new R24 (24 watt) coil. This molded unit is equipped with a rectified 1/2" DIN connection in place of wire leads. Coil assembly is IP65 rated. The R24 solenoid coil does not include the advantages of the Z-Cool Connector: It is continuous duty and operates with a surface temperature of

approximately 220°F when continuously energized for an hour or longer. R24 coil does not include the running light found on the standard W24 coil. R24 provides a lower initial cost, but higher operating cost due to increased energy use. It is best suited for applications requiring periodic energization.

DIMENSIONS

SOLENOID COIL HOUSINGS

Coil Type	A ₁	A ₂	A ₃	B ₁	B ₂
	In. mm	In. mm	In. mm	In. mm	In. mm
W24 IP 65	3.25 83	.80 20	.70 18	2.7 69	2.5 64
R24 IP 65	2.65 67	.80 20	.70 18	2.7 69	1.7 43

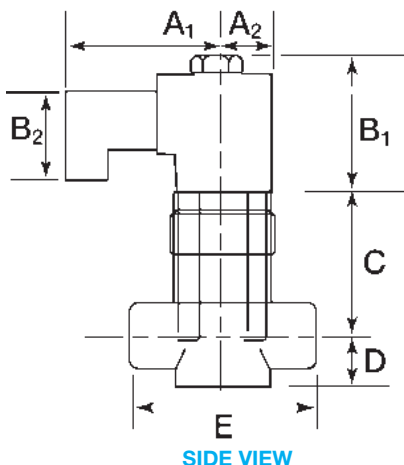

SOLENOID VALVE BODY DIMENSIONS

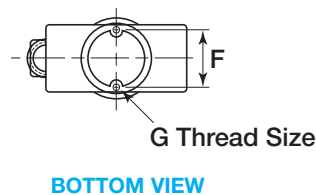

BOTTOM VIEW

W24 SOLENOID COIL HOUSING DIMENSIONS

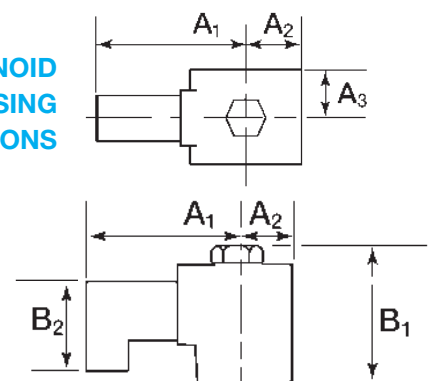

MOLDED VALVE BODIES - SERIES EASYMT & EASMT

Pipe Size	C	D	E	F†	G
	In. mm	In. mm	In. mm	In. mm	Thread Size
1/4" & 1/2"	2.9 73	.94 24	3.3 84	1.5 38	8-32 x 1/2 deep
3/4" & 1"	3.3 84	1.3 33	4.0 102	1.5 38	8-32 x 1/2 deep

† Dimension is from center to center of mounting holes

TECHNICAL INFORMATION

General Information: A solenoid is an electro-mechanical device used to control the opening and closing of a valve. The solenoid consists of several parts; the coil, the plunger (core), the core tube, gaskets, cap nut, spring. Energizing the coil creates a magnetic field which, in a normally closed valve, lifts the disc off of the seat thus opening the valve. In a normally open valve, the solenoid closes the valve when energized. When de-energized a spring returns the valve to its normal position. The action takes about 1/10 of a second. Solenoid valves are considered to be "fast acting" valves. Because they respond to energization so quickly, they can cause water hammer, so it is important to consider and address this when designing your system.

Solenoid Description: The model W24 solenoids consume 24 watts when energized, but when used in conjunction with the connector (valve will not operate without fully assembled coil/connector), the wattage drops to about 1/4 of that value after about 100 milliseconds. A solenoid does not need full power once the valve has changed its position (actuated), and in normal solenoids, once the valve has actuated if it is allowed to remain at full power, that excess energy is wasted in heat. In other words the coil needlessly heats up to a temperature often exceeding that of boiling water. The Plast-O-Matic solenoids will not heat up anywhere near to that temperature. When left energized they heat up slightly, and become warm. This not only vastly reduces the heating, but reduces the energy consumption to about 1/4 of that of normal solenoids. Optional R24 Coil fully and continuously consumes 24 watts when energized and reaches a surface temperature of approximately 220°F when continuously energized.

Solenoid Selection: The model W24 and R24 solenoids are available in AC voltages of 24, 110/120, and 230/240. They will operate at any frequency, i.e. 50 or 60 Hz is acceptable. In DC voltage they are available in 24 volts.

Duty Cycle: All model W24 solenoids are rated at 100% duty cycle at ambient temperatures up to 50° c (122° f). They can be left energized indefinitely (many years) without harm to the solenoid or valve. They can also be rapid cycled. If used at higher ambient temperatures, they must be rated "intermittent". Because there are infinite temperatures that exist, it is not practical to outline the intermittent conditions in this instruction. For particular circumstances it may be advisable to consult the factory or run tests. The solenoid enclosures are rated IP65, safe for outdoor use. Please refer to IP65 specification for specific environmental conditions. Optional R24 Coil is also IP65 rated. Although it is rated for continuous duty, it is best suited for applications requiring periodic energization.

Connector: The W24 solenoid coil and Z-Cool DIN connector MUST be used together. The W24 will not function properly without the Z-Cool DIN connector. Warranty is voided if W24 used without Z-Cool. May be removed temporarily to re-orient direction of wire leads. The wire leads are shipped oriented in a "down" or 6:00 position. The Z-Cool connector can be removed and re-oriented 180° so that direction of wire leads is in an "up" or 12:00 position. Wire direction can only be in these two positions; connector contacts will not align otherwise. After removal and re-orientation of connector, it must be re-tightened immediately. Optional R24 Coil features a DIN connector and does not include wire leads.

W24 Caution: Do not remove W24 Z-Cool connector other than to re-orient wire direction. Do not use any other DIN connector. Do not wire directly to W24 coil contacts. Wiring to W24 coil contacts represents negligence and guarantee is void.

SPECIFICATIONS

STYLE W24
24 Watt
Class "H"
Coils
Continuous Duty



- CORROSION RESISTANT
- CONTINUOUS DUTY
- SAFE OPERATING TEMP.
- IP65 ENCLOSURE



STYLE R24
24 Watt
Class "H"
Coils
Continuous Duty

W 24

Insulation Class	H
Watts (maximum)	24 (watts drop to approx. 6 watts after initially energized)
Duty Cycle	100% (may be energized indefinitely, or rapid on/off cycling is acceptable)
Max. Ambient Temp.	122°F (50°C)
Voltage Tolerance	10% above or below rated voltage.
Current (amps)	See table.
Enclosure Rating	IP65
Wire Leads	18" from Z-Cool DIN
Surface temperature	Maximum of 120°F (48°C) @ 70°F (23°C) ambient.

R 24

Insulation Class	H
Watts (maximum)	24
Duty Cycle	100% (may be energized indefinitely, or rapid on/off cycling is acceptable)
Max. Ambient Temp.	102°F (38°C)
Voltage Tolerance	10% above or below rated voltage.
Current (amps)	See table.
Enclosure Rating	IP65
DIN Connection	1/2" NPT
Surface temperature	Maximum of 220°F (104°C) @ 70°F (23°C) ambient.

W 24	Coil Voltage	Maximum Current (Less Than 1 Second)	Holding Current
	230/240 AC	0.15	0.03
	24 AC	0.85	0.22
	110/120 AC	0.22	0.06
	24 DC	1.1	0.3

AC coils will operate at 50 or 60 Hz.

R 24	Coil Voltage	Maximum Current
	230/240 AC	0.12
	24 AC	1.1
	110/120 AC	0.22
	24 DC	1.1

AC coils will operate at 50 or 60 Hz.

Z-COOL DIN® SOLENOID CONNECTOR

How it Works:

The Z-Cool DIN allows the input line voltage directly to the coil for a fixed duration of 50 milliseconds. After that period, the Z-Cool DIN automatically pulses the input voltage to the coil. The Z-Cool DIN turns the power on and off so fast that the armature does not respond. Because the off period is longer than the on period, the net Root Mean Square (RMS) voltage decreases and wattage is decreased.

Features:

- Enables coils to be energized for extended periods without burnout.
- Saves energy by reducing power consumption by 75%.
- Reduces hold-in voltage to minimize coil heat related losses.
- Increases coil life expectancy.
- Enclosure IP65 rated.
- All versions have an LED indicator light.

PLAST-O-MATIC
VALVES, INC.

1384 Pompton Avenue, Cedar Grove, New Jersey 07009
(973) 256-3000 • Fax (973) 256-4745 • www.plastomatic.com