

TRUE BLUE™ PTFE DIAPHRAGM RELIEF VALVES RVDT/RVDTM ASSEMBLY, INSTALLATION & OPERATING INSTRUCTIONS

A. BEFORE INSTALLING

- Series RVDT/RVDTM valves will open when the inlet pressure exceeds the set pressure when properly installed and used within the recommended ranges of pressure, temperature, and chemical compatibility. The ultimate determination of material

compatibility is previous successful use in the same application. Call our Technical Support for information about your application.

Pressure & Temperature Ratings for Water*

BODY MAT'L	77°F (25°C)	105°F (40°C)	at MAX. TEMP.
PVD	150 PSI; 10 Bar	100 PSI; 7 Bar	40 PSI @ 140°F; 3 Bar @ 60°C
CPVC	150 PSI; 10 Bar	120 PSI; 8 Bar	40 PSI @ 140°F; 3 Bar @ 60°C
PP*	150 PSI; 10 Bar	125 PSI; 8 Bar	40 PSI @ 180°F; 3 Bar @ 80°C
PVDF	150 PSI; 10 Bar	120 PSI; 8 Bar	30 PSI @ 280°F; 2 Bar @ 140°C
PTFE	150 PSI; 10 Bar	140 PSI; 9 Bar	10 PSI @ 280°F; 69 KPa @ 140°C

* or compatible chemical - Ratings may be reduced for some applications. Typical burst pressure is 4 times rating or more.

- Minimum temperature 40°F (5°C)

B. INSTALLATION

- The valve must be installed in the proper flow direction s indicated by the flow label. All orientations, horizontal and vertical, are suitable. Relief valves should be installed as close as possible to the vessel or pipe which it is protecting.
- Caution:** Series RVDT/RVDTM is not a “pop safety” relief valve. It is not intended for air or gas service. It does not regulate pressure downstream of the valve. Caution: Plastic materials can degrade in ultraviolet (UV) light or sunlight.
- Visual Identification of Material

BODY MATERIAL	COLOR
“PV” (Geon) (PVC)	DARK GRAY
“CP” (Corzan) (CPVC)	LIGHT GRAY
“PP” (Polypropylene)	TRANSLUCENT WHITE
“PF” (Kynar) (PVDF)	TRANSLUCENT WHITE/YELLOW
“TF” (Teflon)	OPAQUE WHITE

Caution: Polypropylene and PVDF (Kynar) often look similar and may be difficult to distinguish by color. Do not install in your system if you are not sure.

- Threaded Connections – A suitable thread sealant (ex. Teflon tape) should be applied to make tapered threads to assure a “leak-tight”

seal. The assembly need only be made “hand-tight” followed by a quarter (1/4) turn with a strap wrench. Do not over tighten or use pipe wrenches on plastic pipe and components.

Caution: Teflon tape will “string” as pipe threads are joined. Loose “strings” could lay across the seating surface and prevent the valve from completely closing. To avoid this problem, clean out old tape, and do not apply tape to the first thread. connections should be made only to plastic fittings; metal pipe should only be installed with an intervening plastic nipple. Metal pipe and straight threaded pipe tend to cut, stretch, and distort the plastic bodies, which could result in cracking or leaking over time.

- Non-Threaded Connections – for solvent cementing o heat fusion, contact your distributor.

C. OPERATION & SETTING

- Relief Valve Operations – The function of a relief valve is to protect a pressurized pipeline, vessel, or other similar system from excessive pressure. When the inlet pressure exceeds the set point, the valve opens to bleed off the excess pressure.

- Back Pressure Operations – A back pressure valve maintains pressure in a line or system. Excess pressure opens the valve, keeping the inlet pressure at the set point.

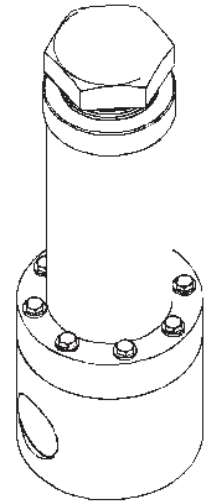

TRUE BLUE™ PTFE DIAPHRAGM RELIEF VALVES RVDT/RVDTM ASSEMBLY, INSTALLATION & OPERATING INSTRUCTIONS

Pressure Setting for Relief or Back Pressure

1. Connect the valve inlet to a pressurized line which is at the desired setpoint and gaged.
2. Where pressurized air is used for setting, run a line from the valve outlet into a container of water, or fill the outlet port with water. Otherwise run a line to a drain.
3. If flow is detected, turn the adjusting screw in until flow stops.
4. Slowly turn the adjusting screw out until a small flow is detected.
3. By-pass Operations – A by-pass valve is installed on a tee in the outlet piping of a pump to prevent dead-heading and/or control the pump's outlet pressure. When pressure exceeds the set point, the valve opens to allow the liquid to recycle (by-pass) to the pump inlet.

Caution: line pressure at the valve outlet (the pump inlet) can open the valve, allowing reverse flow.

3. By-pass Operation – A by-pass valve is installed on a tee in the outlet piping of a pump to prevent dead-heading and/or control the pump's outlet pressure. When pressure exceeds the set point, the valve opens to allow the liquid to recycle (by-pass) to the pump inlet.

Caution: line pressure at the valve outlet (the pump inlet) can open the valve, allowing reverse flow.

Pressure Setting for By-pass

1. Install the valve. Turn the adjusting screw all the way in.
2. with the pump running normally at a pressure above the desired point, turn the adjusting screw out to reach the desired pressure.

D. PARTS & ILLUSTRATION

#	QTY.	DESCRIPTION	MAT'L
1	1	BODY	see B.3.
2	1	SPRING HOUSING	PVC
3	1	LOCK RING	HDPE
4	1	ADJUSTING SCREW	HDPE
5	1	DIAPHRAGM SUPPORT	PVC
6	1	U-CUP SEAL	VITON FKM
7	4	HEX HEAD SCRW	SS
8	4	LOCK WASHER	SS
9	X	SPRING(S) see table next pg	STEEL
10	1	SEALING DIAPHRAGM	PTFE
11	1	BACKING DIAPHRAGM	VITON FKM

Exact appearance varies by size and/or body style.

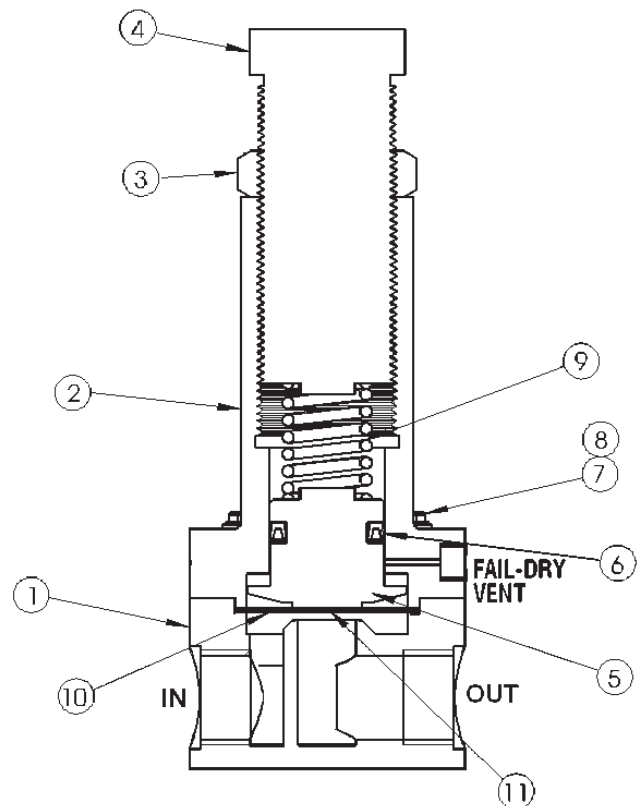

TRUE BLUE™ PTFE DIAPHRAGM RELIEF VALVES RVDT/RVDTM

ASSEMBLY, INSTALLATION & OPERATING INSTRUCTIONS

D. MAINTENANCE

A. Seal Kits – Plast-O-Matic recommends keeping a spare seal kit available for repairs. Seal life will vary in applications due to cycles, temperatures, pressures, chemicals, and concentration. Based on the application, a periodic inspection and maintenance plan should be established. The part number for a seal kit is SK plus the valve part number less the material suffix. for example, RVDT050V-PV needs a seal kit SKRVDT050V.

B. Changing Range of Adjustment – Range of pressure adjustment can be changed by changing or combining springs. Unscrew the adjusting screw all the way and remove. Add or remove springs. Replace the adjusting screw.

PART NO.	PIPE SIZE	ADJUST RANGE	SPRINGS
RVDT025T	1/4"	5-40	LC112L-2
		41-100	LC112L-2 & LC112J-5
RVDT050T	1/2"	5-50	LC135M-0
		51-100	LC135M-0 & LC112J-4
RVDT075T	3/4"	5-50	LHC162N-0
		51-100	LC112J-7 & LHC162N-0
RVDT100T <i>OR</i> RVDTM100T	1"	5-100	LC135M-3 LHC234T-2
RVDT150T	1½"	5-100	LHL200A-4
RVDT200T	2"	5-100	LHL100A-8 & LHL200B-4