

Series UPR ULTRA-PURE PRESSURE REGULATORS

INSTALLATION & MAINTENANCE INSTRUCTIONS

IMPORTANT – BEFORE INSTALLING

Series UPR Pressure Regulators will prevent downstream pressure from exceeding the set pressure, when properly installed and used within the recommended ranges of pressure, temperature, and chemical compatibility. The ultimate determination of material compatibility is previous successful use in the same application. See the Series UPR Product Data Sheet or call our Technical Support for information about your application.

Caution:

1. Plastic materials will degrade in ultraviolet (UV) light or sunlight.
2. Polypropylene and PVDF (Kynar) look similar. Do not install if you are not sure.
3. Quick closing valves installed downstream of the regulator can cause water hammer. This may cause leakage, diaphragm or seal damage.

RATINGS AND SPECIFICATIONS

Set Pressure Range 5-100 PSI 3.4 to 7 Bar

MAXIMUM INLET PRESSURES FOR WATER*

Body Material	Color	77°F (25°C)	104° (40°C)	At Maximum Temperature
Kynar	Translucent	150 PSI	120 PSI	22.5 PSI @ 280°F
PVDF	White (Yellowish)	10.3 Bar	8.27 Bar	1.5 Bar @ 140° C

*or compatible chemical - ratings reduced for some applications. Minimum temperature 40°F (5°C). Call technical support if further information is needed.

INSTALLATION INSTRUCTIONS

Install the valve in the proper flow direction as indicated by the flow label. The valve may be mounted vertically or horizontally.

Spigot Connections – For heat fusion, follow the instructions supplied with the fusion equipment, or contact your distributor.

Mounting – The piping must be properly supported, taking into account the weight of the valve, piping, and process liquid. A bracket or shelf to support the valve must be used.

PRESSURE SETTINGS INSTRUCTIONS

Series UPR and pressure regulators sense downstream pressure; therefore it may be helpful to install a pressure gauge at the outlet of the valve for setting. The pressure must be set dynamically (with flow) using this procedure.

1. Install the regulator in the piping system. Close all outlets to stop flow. The inlet pressure must be higher than the desired set pressure.
2. If the outlet pressure is low, increase spring force until the set pressure is reached.
3. If the outlet pressure is high, reduce spring force until the set pressure is reached*.

*Series UPR regulators are non-relieving. Outlet pressure will not drop unless the outlet is open to lower pressure.

continued. . .

Series UPR Pressure Regulators prevent downstream pressure from exceeding the desired “set” pressure.

The “set” pressure can be adjusted by means of the adjusting screw on top of the regulator.

Rotating the screw Clockwise (CW) increases the pressure.

Rotating the screw Counterclockwise (CCW) decreases the pressure.

Increased Flow, caused by equipment downstream of regulator, will cause a decrease in the outlet pressure. This is known as droop.

Decreased Flow, caused by equipment downstream of regulator, will cause increase in the outlet pressure.

CAUTIONARY NOTE:

This regulator will never close off flow completely. It **DOES NOT** provide positive shut-off. Therefore, if the demand goes below that value at which the regulator was set, the outlet pressure will rise above the set point and if the demand is stopped (no flow condition) the outlet pressure will rise up to the value of the inlet pressure. If excessive pressure can damage downstream equipment a shut-off valve must be placed between the regulator and the equipment in question. For flow and droop rates, refer to catalog UPR.

MAINTENANCE

Plast-O-Matic recommends keeping a spare seal kit available for repairs. Seal life will vary in applications due to cycles, temperatures, pressures, chemicals, and concentration. Based on the application, a periodic inspection and maintenance plan should be established. The seal kit part number is “SK” plus the part number less the material suffix. For example, the seal kit for UPR050TPF-SO is SKUPR050TPF-SO.

PARTS LIST

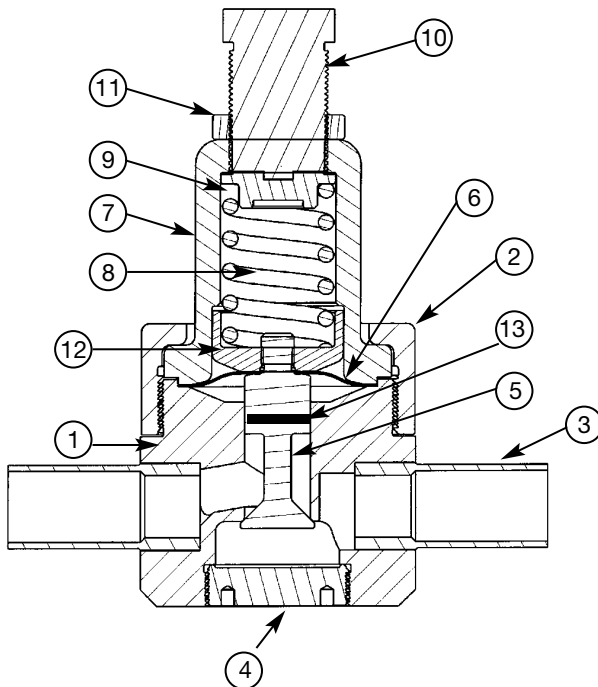

Item #	Qty	Description
1	1	BODY
2	1	UNION NUT
3	2	SPIGOT
4	1	BASE PLUG
5	1	STEM PVDF
6	1	DIAGPHRAM
7	1	SPRING HOUSING
8	1	SPRING
9	1	SPRING GUIDE
10	1	ADJUSTING SCREW
11	1	LOCK NUT
12	1	SPRING RETAINER
13	1	PISTON RING