

## DAB Series Flanged Diaphragm Valves

1/2" TO 10" PP AND 1/2" TO 8" PVDF

### KEY FEATURES

- 1/2" to 10" PP and 1/2" to 8" PVDF
- Position Indicator
- Sure-Grip Handwheel
- Choice of FPM, EPDM or PTFE Diaphragms\*

### OPTIONS

- Pneumatic or Electric Actuation to 4" \*\*
- PVDF Vapor Barrier\*\*\*

### MATERIALS

- PP per ASTM D4101
- PVDF

\* All PTFE diaphragms are EPDM backed  
 \*\* Over 4" Actuation, Consult Factory  
 \*\*\* PVDF Vapor Barrier available with EPDM and PTFE diaphragm only



## TECHNICAL INFORMATION

### EXPLODED VIEW



### SELECTION CHART

SIZE	MATERIAL	END CONNECTION	DIAPHRAGM	PRESSURE RATING
1/2" – 4" (DN15 – DN100)	PP	Flanged	FPM, EPDM, PTFE or PVDF Vapor Barrier	150 PSI @ 70°F Non-Shock
6" – 10" (DN150 – DN250)				75 PSI @ 70°F Non-Shock
1/2" – 4" (DN15 – DN100)	PVDF		PTFE	150 PSI @ 70°F Non-Shock
6" – 8" (DN150 – DN200)				75 PSI @ 70°F Non-Shock

# DAB Series Flanged Diaphragm Valves

1/2" TO 10" PP AND 1/2" TO 8" PVDF

## TECHNICAL INFORMATION, CONTINUED

### 1/2" – 10" PARTS LIST (A)

- |                  |                           |
|------------------|---------------------------|
| 1. Gauge Cap     | 10. Spindle               |
| 2. Stopper Nut   | 11. Compressor            |
| 3. Lock Nut      | 12. Diaphragm             |
| 4. Hand Wheel    | 13. Body                  |
| 5. Thrust Washer | 14. Diaphragm Cover Plate |
| 6. Bonnet        | 15. Washer                |
| 7. Sleeve        | 16. Pin                   |
| 8. Bolt and Nut  |                           |
| 9. Stem          |                           |

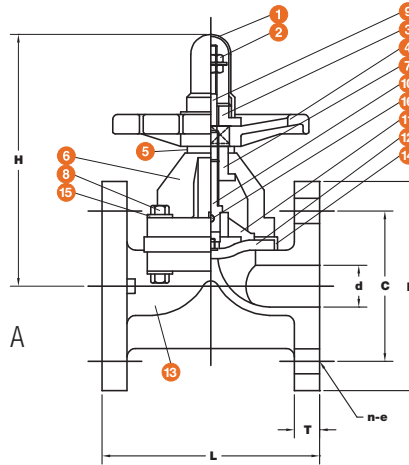

### 1/2" – 8" PARTS LIST (B)

- |                  |                         |
|------------------|-------------------------|
| 1. Gauge Cap     | 11. Body                |
| 2. Stopper Nut   | 12. Diaphragm           |
| 3. Lock Nut      | 13. Pin                 |
| 4. Hand Wheel    | 14. Washer              |
| 5. Thrust Washer | 15. PTFE Ring           |
| 6. Bonnet        | 16. Inserted Nut        |
| 7. Sleeve        | 17. Thrust Ball Bearing |
| 8. Bolt and Nut  | 18. Grease Nipple       |
| 9. Stem          | 19. SUS Plate           |
| 10. Compressor   | 20. Body O-Ring         |

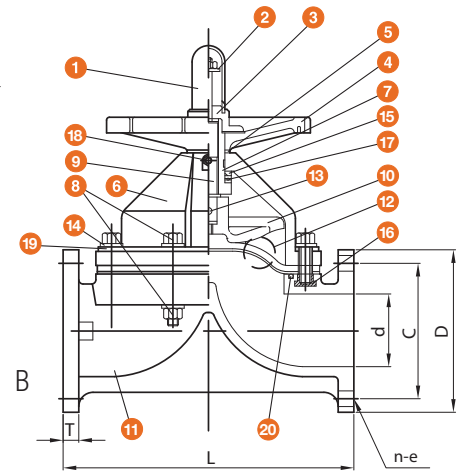

### DIMENSIONS – INCHES / MILLIMETERS

SIZE in / DN	C in / mm	d in / mm	D in / mm	H in / mm	L in / mm	T in / mm	n-e # x diameter
1/2 / 15	2.38 / 60	.63 / 16	3.50 / 89	3.78 / 96	4.33 / 110	.47 / 12	4-15.7
3/4 / 20	2.76 / 70	.79 / 20	3.86 / 98	3.94 / 100	4.72 / 120	.51 / 13	4-15.7
1 / 25	3.13 / 80	.98 / 25	4.25 / 108	4.25 / 108	5.20 / 132	.55 / 14	4-15.7
1-1/4 / 32	3.50 / 89	1.20 / 30	4.65 / 118	5.75 / 146	5.20 / 132	.55 / 14	4-15.7
1-1/2 / 40	3.85 / 98	1.60 / 41	5.00 / 127	7.76 / 197	7.09 / 180	.63 / 16	4-15.7
2 / 50	4.75 / 121	2.00 / 51	6.00 / 152	8.58 / 218	8.27 / 210	.70 / 18	4-19
2-1/2 / 63	5.50 / 140	2.55 / 65	6.90 / 175	10.24 / 260	9.88 / 251	.79 / 20	4-19
3 / 80	6.00 / 152	3.03 / 77	7.50 / 191	10.63 / 270	11.02 / 280	.83 / 21	4-19
4 / 100	7.50 / 191	3.94 / 100	9.00 / 229	11.81 / 300	13.50 / 343	.83 / 21	8-19
6 / 150	9.50 / 241	5.70 / 145	11.00 / 279	18.74 / 476	18.80 / 478	1.06 / 27	8-22
8 / 200	11.70 / 297	7.64 / 194	13.50 / 343	24.69 / 627	22.44 / 570	1.24 / 31	8-22
10 / 250*	14.25 / 362	9.72 / 247	16.00 / 406	17.55 / 699	26.70 / 678	1.46 / 37	12-25

Dimensions are subject to change without notice – consult factory for installation information

\* 10" available in PP only

### Cv VALUES

SIZE in / DN	Cv VALUES GPM	SIZE in / DN	Cv VALUES GPM	SIZE in / DN	Cv VALUES GPM	SIZE in / DN	Cv VALUES GPM
1/2 / 15	5.0	1-1/4 / 30	18.0	2-1/2 / 63	80.0	6 / 150**	400.0
3/4 / 20	8.0	1-1/2 / 40	26.0	3 / 80	115.0	8 / 200	700.0
1 / 25	10.0	2 / 50	56.0	4 / 100	190.0	10 / 250	1000.0



Hayward is a registered trademark of Hayward Industries, Inc. © 2011 Hayward Industries, Inc.

Contact Hayward Flow Control with questions: 1-888-429-4635 • Fax: 1-888-778-8410 • One Hayward Industrial Drive • Clemmons, NC 27012 • USA  
Visit us at: www.haywardflowcontrol.com • E-mail: hflow@haywardnet.com