

GATE VALVE

Hand wheel Model



Cap(Square Nut)



Rising Stem



Threaded Body



Stem Extension



FEATURES

High Corrosion and Impact-resistance

All wet sections are made of corrosion-resistant material, thus preventing corrosion and turbid water due to rust, The GATE VALVE, made of high impact polyvinyl chloride, can be used for water supply and drainage.

Light and Rugged Structure

Being made of synthetic resin, the ASAHI AV GATE VALVE is about 1/5 the weight of a cast iron gate valve. However, the ASAHI AV GATE VALVE gives the same torque strength as a cast iron gate valve, so it endures high torque.

Flexibility Covering Flow Variations

The gate valve is so flexible in covering many flow variations with tight shut-off.

Easy Maintenance

The stem sealed with an O-ring, prevents external leaks and is easy to replace.

NSF Product

NSF("NSF/ANSI STANDARD 61" Drinking Water System Components-Health Effects)Product.

:GATE VALVE TYPE P(Plug) (Material:PVC+EPDM,FKM)

*Certified products bear an NSF Certification Mark.

SPECIFICATIONS

Body material	Valve:High Impact Polyvinyl Chloride(HI-PVC)
Gate material	TYPE-P :32mm(1 1/4inch) to 350mm(14inch) ...PP Soft seals:32mm(1 1/4inch) to 150mm(6inch)HI-PVC+SBR 65mm(2 1/2inch), 125mm(5inch)C-PVC+SBR
Nominal size	Popular series (Type P):40 to 350mm(1 1/2inch to 14inch) Resilient series(Type S):40 to 200mm(1 1/2inch to 8inch)
Working Temperature	- 10°C - 50°C (15° F - 120° F)
Max. Working Pressure	40mm(1 1/2inch) - 200mm(8inch) 1.0Mpa{10.2kgf/cm ² } [150PSI] 250mm(10inch) 0.75Mpa{7.7kgf/cm ² } [110PSI] 300mm(12inch), 350mm(14inch) 0.5Mpa{5.1kgf/cm ² } [70PSI]
End Connectors	Flanged End Threaded Type(40mm,50mm)are available.
Mechanism	Round Handle, Cap (Square Nut), Stem Extension

WORKING PRESSURE VS. TEMPERATURE

GATE VALVE

Gate Valve TypeP, Type S

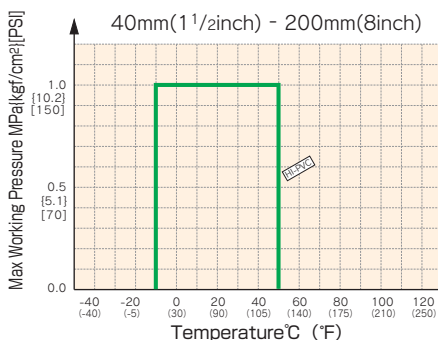

Gate Valve TypeP, Type S

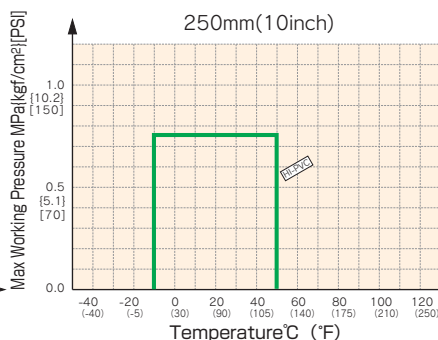

Gate Valve TypeP, Type S

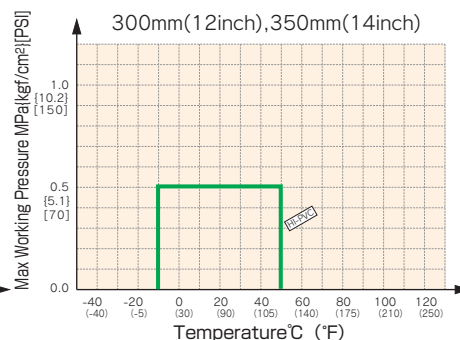

GATE VALVE TYPE-P(Plug) 40mm - 350mm(1½inch - 14inch)

● 40mm (1½inch) – 150mm (6inch)

● 200mm (8inch) – 350mm (14inch)

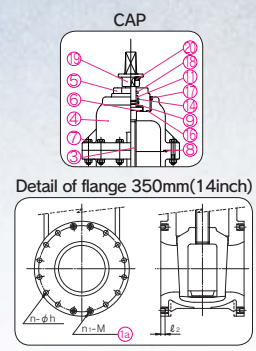
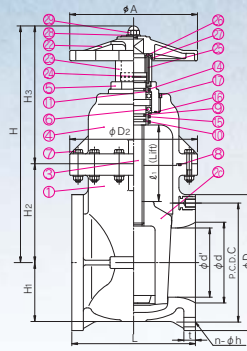
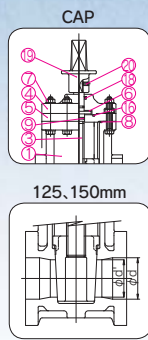
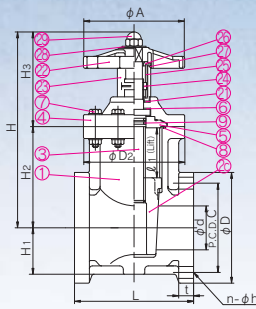

Gate valves 125mm or more in nominal size have a reduced flow channel.

PARTS & MATERIALS

No.	DESCRIPTION	Pcs.	MATERIAL	No.	DESCRIPTION	Pcs.	MATERIAL	No.	DESCRIPTION	Pcs.	MATERIAL
①	BODY	1	HI-PVC	⑨	O-RING(C)	2	EPDM, Others	⑳	INDICATING COVER	1	PC
①a	INSERTED METAL OF STEM	—	COPPER ALLOY(C3604)	⑩	BUSHING(A)	1	PP	㉑	INDICATING RING	1	PVC
②	GATE(A)	1	PP	⑪	BUSHING(B)	1	PP	㉒	GUIDE PIN	1	STAINLESS STEEL304
③	STEM	1	PVC	⑬	O-RING(E)	1	EPDM, Others	㉓	GUIDE PIN HOLDER	1	PVC
④	BONNET(A)	1	HI-PVC	⑭	O-RING(F)	1	EPDM, Others	㉔	O-RING(G)	1	EPDM
⑤	BONNET(B)	1	HI-PVC	⑮	O-RING(D)	1	EPDM, Others	㉕	WASHER	1	PVC
⑥	THRUST RING	1set	PP, SUJ2	⑯	SET SCREW(A)	1	STAINLESS STEEL304	㉖	BOX NUT	1	STAINLESS STEEL304
⑦	BOLT·NUT	—	STAINLESS STEEL304	⑰	PACKING	1	EPDM				
⑧	O-RING(B)	1	EPDM, Others	⑱	HAND WHEEL	1	PP				

DIMENSIONS TABLE

Nominal Size		d	d'	FLANGE END JIS 10K								THREAD END								Unit:mm	
mm	inch			D	C	n	h	n ₁	M	L	t	d ₂	ℓ	L	D ₂	ℓ ₁	H	H ₁	H ₂	H ₃	A
32	1¼	40	30	135	100	4	19	—	—	165	22	Rc1¼	22	115	120	49	239	50	107	132	120
40	1½	40	40	140	105	4	19	—	—	165	22	Rc1½	25	115	120	49	239	50	107	132	120
50	2	50	50	155	120	4	19	—	—	180	23	Rc2	28	130	130	60	270	58	134	136	130
65	2½	65	—	175	140	4	19	—	—	190	24	—	—	—	155	75	302	68	152	150	155
80	3	75	—	185	150	8	19	—	—	200	25	—	—	—	170	85	325	77	170	155	170
100	4	100	—	210	175	8	19	—	—	230	27	—	—	—	195	110	370	89	207	163	195
125	5	125	110	250	210	8	23	—	—	260	27	—	—	—	235	117	407	89	227	180	235
150	6	150	130	280	240	8	23	—	—	270	28	—	—	—	270	138	445	102	263	182	270
200	8	196	168	330	290	10	23	2	M20	290	28	—	—	—	310	180	577	143	240	337	310
250	10	247	210	400	355	12	25	—	—	380	30	—	—	—	360	226	690	175	270	420	360
300	12	298	255	445	400	14	25	2	M22	400	31	—	—	—	410	273	800	195	320	480	410
350	14	348	297	490	445	12	25	4	M22	430	32	—	—	—	440	319	910	230	310	600	455

Nominal Size		d	d'	d'₂	FLANGE END DIN PN 10								THREAD END								Unit:mm	
mm	inch				D	C	n	h	n ₁	M	L	t	d ₂	ℓ	L	D ₂	ℓ ₁	H	H ₁	H ₂	H ₃	A
40	1½	40	—	40	150	110	4	18	—	—	165	22	Rp1½	25	115	120	49	239	50	107	132	120
50	2	50	—	50	165	125	4	18	—	—	180	23	Rp2	28	130	130	60	270	58	134	136	130
65	2½	65	—	—	185	145	4	18	—	—	210	24	—	—	—	155	75	302	68	152	150	155
80	3	75	—	—	200	160	8	18	—	—	240	25	—	—	—	170	85	325	77	170	155	170
100	4	100	—	—	220	180	8	18	—	—	250	27	—	—	—	195	110	370	89	207	163	195
125	5	125	110	—	250	210	8	18	—	—	260	27	—	—	—	235	117	407	89	227	180	235
150	6	150	130	—	285	240	8	22	—	—	280	27	—	—	—	270	138	445	102	263	182	270
200	8	196	168	—	340	295	6	22	2	M20	300	28	—	—	—	310	180	577	143	240	337	310
250	10	247	210	—	395	350	12	22	—	—	380	30	—	—	—	360	226	690	175	270	420	360
300	12	298	255	—	445	400	10	22	2	—	400	31	—	—	—	410	273	800	195	320	480	410
350	14	348	297	—	505	460	12	22	4	—	430	32	—	—	—	440	319	910	230	310	600	455

Nominal Size		d	d'	FLANGE END ANSI Class 150								THREAD END								Unit:inch	
inch	mm			D	C	n	h	n ₁	M	L	t	d ₂	ℓ	L	D ₂	ℓ ₁	H	H ₁	H ₂	H ₃	A
1½	40	1.57	1.57	5.00	3.88	4	0.62	—	—	6.50	0.87	1½-11½NPT	0.98	4.53	4.72	1.93	9.41	2.48	4.21	5.20	4.72
2	50	1.97	1.97	6.00	4.75	4	0.75	—	—	7.00	0.91	2-11½NPT	1.10	5.12	5.12	2.36	10.63	2.80	5.28	5.35	5.12
2½	65	2.56	—	7.00	5.50	4	0.75	—	—	7.50	0.94	—	—	—	6.10	2.95	11.89	3.19	5.98	5.91	6.10
3	80	2.95	—	7.00	6.00	4	0.75	—	—	8.00	0.98	—	—	—	6.69	3.35	12.80	3.54	6.69	6.10	6.69
4	100	3.94	—	9.00	7.50	8	0.75	—	—	9.00	1.06	—	—	—	7.68	4.33	14.57	4.02	8.15	6.42	7.68
5	125	4.92	4.33	10.00	8.50	8	0.88	—	—	10.24	1.06	—	—	—	9.25	4.61	16.02	4.17	8.94	7.09	9.25
6	150	5.91	5.12	11.00	9.50	8	0.88	—	—	10.50	1.06	—	—	—	10.63	5.43	17.52	4.69	10.35	7.17	10.63
8	200	7.72	6.61	13.50	11.75	6	0.88	2	W¾	11.50	1.30	—	—	—	12.2	7.09	22.72	6.3	9.45	13.27	12.2
10	250	9.72	8.27	16.00	14.25	12	1.00	—	—	14.96	1.18	—	—	—	14.17	8.9	27.17	7.56	10.63	16.54	14.17
12	300	11.73	10.04	19.00	17.00	10	1.00	2	W7/8	15.75	1.22	—	—	—	16.14	10.75	31.5	8.35	12.6	18.9	16.14
14	350	13.70	11.69	21.00	18.75	8	1.12	4	W1	16.93	1.26	—	—	—	17.32	12.56	35.83	9.72	12.21	23.62	17.91

GATE VALVE TYPE-S (Soft Seal) 50mm - 200mm(2inch - 8inch)

Hand Wheel

FEATURES

Reliable Watertightness

The rubber valve seat, a soft seal type, offers reliable shut-off.

Provides Smooth Flow

Being free of cavities, the valve body has no sand or foreign matter build up in it, thus providing a smooth flow.

※ Threaded End Type (40mm, 50mm) are available.

●50mm(2inch)~150mm(6inch) (STEM:PVC)

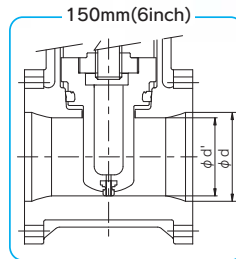
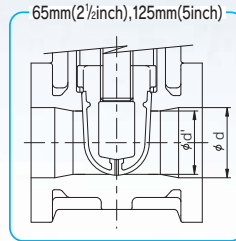
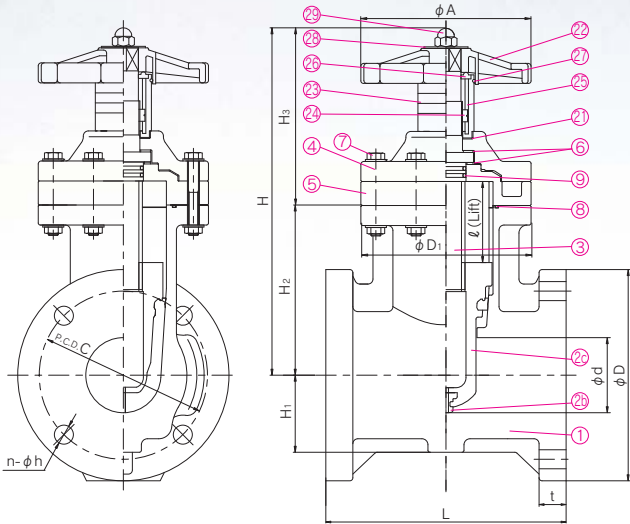

●200mm(8inch) (STEM:PVC)

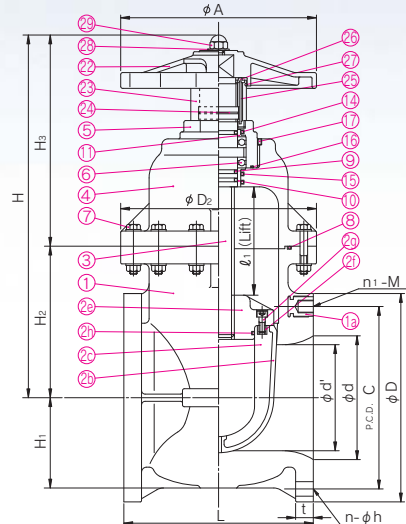

PARTS & MATERIALS

No.	DESCRIPTION	Pcs.	MATERIAL	No.	DESCRIPTION	Pcs.	MATERIAL	No.	DESCRIPTION	Pcs.	MATERIAL
①	BODY	1	HI-PVC	⑥	THRUST RING	2	PP,SUJ2	⑰	SET SCREW(A)	1	STAINLESS STEEL304
⑱	INSERTED METAL OF BODY	4	COPPER ALLOY(C3604)	⑦	BOLT·NUT	—	STAINLESS STEEL304	⑳	PACKING	1	EPDM
㉒	SEAT	1	SBR,NBR	㉑	O-RING(A)	1	EPDM, Others	㉓	HAND WHEEL	1	PP
㉔	GATE(A)	1	HI-PVC,C-PVC	⑧	O-RING(B)	1	EPDM, Others	㉔	INDICATING COVER	1	PC
㉕	GATE(B)	1	PP	⑨	O-RING(C)	2-3	EPDM, Others	㉕	INDICATING RING	1	PVC
㉖	INSERTED METAL OF GATE(A)	4	COPPER ALLOY(C3604)	⑭	O-RING(E)	1	EPDM, Others	㉖	GUIDE PIN	1	STAINLESS STEEL304
㉗	BOLT(A)	4	STAINLESS STEEL304	⑮	O-RING(F)	1	EPDM, Others	㉗	GUIDE PIN HOLDER	1	PVC
③	STEM	1	PVC	⑯	O-RING(D)	1	EPDM, Others	㉘	O-RING(G)	1	EPDM
④	BONNET(A)	1	HI-PVC	⑩	BUSH(A)	1	PP	㉙	WASHER	1	PVC
⑤	BONNET(B)	1	HI-PVC	⑪	BUSH(B)	1	PP	㉚	BOX NUT	1	STAINLESS STEEL304

DIMENSIONS TABLE

Nominal Size		d	d ₁	JIS 10K					L	t	D ₁	A	ℓ	H	H ₁	H ₂	Unit:mm
mm	inch			D	C	n	h	n ₁ -M									
50	2	50	—	155	120	4	19	—	180	23	130	130	52	293	58	134	
65	2 1/2	65	—	175	140	4	19	—	210	24	155	155	67	302	68	152	
80	3	75	—	185	150	8	19	—	240	25	170	170	77	350	77	170	
100	4	100	—	210	175	8	19	—	250	27	195	195	102	410	89	207	
125	5	125	110	250	210	8	23	—	260	27	235	235	112	407	89	227	
150	6	150	130	280	240	8	23	—	280	28	270	270	132	487	117	263	
200	8	196	168	330	290	10	23	2-M20	290	28	310	310	175	577	143	240	

Nominal Size		d	d ₁	DIN PN10					L	t	D ₁	A	ℓ	H	H ₁	H ₂	Unit:mm
mm	inch			D	C	n	h	n ₁ -M									
50	2	50	—	165	125	4	18	—	180	23	130	130	52	293	58	134	
65	2 1/2	65	—	185	145	4	18	—	210	24	155	155	67	302	68	152	
80	3	75	—	200	160	8	18	—	240	25	170	170	77	350	77	170	
100	4	100	—	220	180	8	18	—	250	27	195	195	102	410	89	207	
125	5	125	110	250	210	8	18	—	260	27	235	235	112	407	89	227	
150	6	150	130	285	240	8	23	—	280	28	270	270	132	487	117	263	
200	8	196	168	340	295	6	23	2-M20	290	28	310	310	175	577	143	240	

Nominal Size		d	d ₁	ANSI CLASS 150					L	t	D ₁	A	ℓ	H	H ₁	H ₂	Unit:inch
inch	mm			D	C	n	h	n ₁ -M									
2	50	1.97	—	5.98	4.74	4	0.75	—	7.01	0.91	5.12	5.12	2.05	10.63	5.28	5.35	
2 1/2	65	2.56	—	7.01	5.49	4	0.75	—	7.48	0.94	6.10	6.10	2.64	11.89	5.98	5.91	
3	80	2.95	—	7.52	6.00	4	0.75	—	7.99	0.98	6.69	6.69	3.03	12.79	6.69	6.10	
4	100	3.94	—	9.02	7.50	8	0.75	—	9.02	1.06	7.68	7.68	4.02	14.57	8.15	6.42	
5	125	4.92	4.33	10.00	8.50	8	0.87	—	10.24	1.06	9.25	9.25	4.41	16.03	8.94	7.09	
6	150	5.91	5.12	10.98	9.51	8	0.87	—	10.51	1.06	10.63	10.63	5.20	17.52	10.35	7.17	
8	200	7.72	6.61	13.50	11.75	6	0.87	2-W ³ / ₄	11.50	1.10	12.20	12.20	6.89	22.72	9.45	13.27	

GATE VALVE TYPE-S (Soft Seal) 50mm - 200mm(2inch - 8inch)

Cap(square Nut) Model

FEATURES

Built-in Stopper

Feeling in the shut, position.

Reliable Watertightness

The rubber valve seat, a soft seal type, offers reliable shut-off.

Provides Smooth Flow

Being free of cavities, the valve body has no sand or foreign matter build up in it, thus providing a smooth flow.

※ Threaded End Type (40mm, 50mm)are available.

● 32mm(1¹/₄inch) – 150mm(6inch)
(basides 65mm(2¹/₂inch), 125mm(5inch))

● 65mm(2¹/₂inch), 125mm(5inch) ● 200mm(8inch)

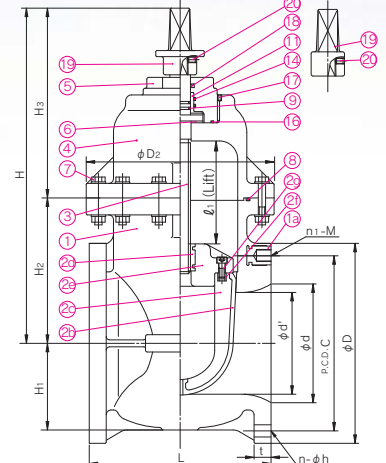
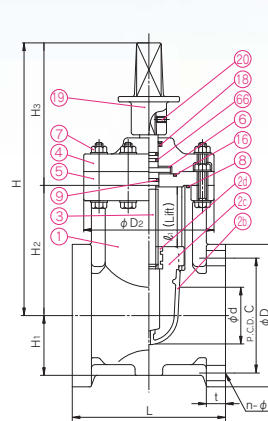
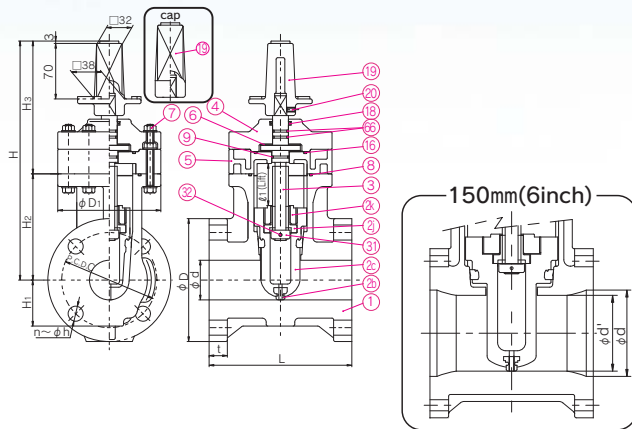

PARTS & MATERIALS

No.	DESCRIPTION	Pcs.	MATERIAL	No.	DESCRIPTION	Pcs.	MATERIAL	No.	DESCRIPTION	Pcs.	MATERIAL
①	BODY	1	HI-PVC	⑭	FEMALE SCREW HOLDER	1	HI-PVC	⑩	O-RING(D)	1	EPDM, Others
①a	INSERTED METAL OF BODY	4	COPPER ALLOY(C3604)	⑮	STEM	1	SUS304, Others	⑪	BUSH(A)	1	PP
②a	SEAT	1	SBR, NBR	⑯	BONNET(A)	1	HI-PVC	⑫	BUSH(B)	1	PP
②b	GATE(A)	1	C-PVC	⑰	BONNET(B)	1	HI-PVC	⑬	SET SCREW(A)	1	STAINLESS STEEL304
②c	INSERTED METAL OF GATE(A)	1	BC6	⑱	THRUST RING	2	PP	⑭	DUST SEAL	1	EPDM
②d	GATE(B)	1	PP	⑲	BOLT · NUT	—	STAINLESS STEEL304	⑮	CAP(A)	1	FCD450, FC200(65,125,200mm)
②e	INSERTED METAL OF GATE(B)	4	COPPER ALLOY(C3604)	⑳	O-RING(B)	1	EPDM, Others	⑯	SET SCREW(B)	1	STAINLESS STEEL304
②f	BOLT(A)	4	STAINLESS STEEL304	㉑	O-RING(C)	1·2	EPDM, Others	⑰	O-RING(H)	2	EPDM
②g	FEMALE SCREW METAL	1	COPPER ALLOY(C3604)	㉒	O-RING(E)	2	EPDM, Others				

DIMENSIONS TABLE

Nominal Size		d	d ₁	JIS 10K					L	t	D ₁	A	ℓ	H	H ₁	H ₂
mm	inch			D	C	n	h	n ₁ -M								
50	2	50	—	155	120	4	19	—	180	23	130	130	52	293	58	134
65	2 ¹ / ₂	65	—	175	140	4	19	—	210	24	155	155	67	302	68	152
80	3	75	—	185	150	8	19	—	240	25	170	170	77	350	77	170
100	4	100	—	210	175	8	19	—	250	27	195	195	102	410	89	207
125	5	125	110	250	210	8	23	—	260	27	235	235	112	407	89	227
150	6	150	130	280	240	8	23	—	280	28	270	270	132	487	117	263
200	8	196	168	330	290	10	23	2-M20	290	28	310	310	175	577	143	240

Nominal Size		d	d ₁	DIN PN10					L	t	D ₁	A	ℓ	H	H ₁	H ₂
mm	inch			D	C	n	h	n ₁ -M								
50	2	50	—	165	125	4	18	—	180	23	130	130	52	293	58	134
65	2 ¹ / ₂	65	—	185	145	4	18	—	210	24	155	155	67	302	68	152
80	3	75	—	200	160	8	18	—	240	25	170	170	77	350	77	170
100	4	100	—	220	180	8	18	—	250	27	195	195	102	410	89	207
125	5	125	110	250	210	8	18	—	260	27	235	235	112	407	89	227
150	6	150	130	285	240	8	23	—	280	28	270	270	132	487	117	263
200	8	196	168	340	295	6	23	2-M20	290	28	310	310	175	577	143	240

Nominal Size		d	d ₁	ANSI CLASS 150					L	t	D ₁	A	ℓ	H	H ₁	H ₂
inch	mm			D	C	n	h	n ₁ -M								
2	50	1.97	—	5.98	4.74	4	0.75	—	7.01	0.91	5.12	5.12	2.05	10.63	5.28	5.35
2 ¹ / ₂	65	2.56	—	7.01	5.49	4	0.75	—	7.48	0.94	6.10	6.10	2.64	11.89	5.98	5.91
3	80	2.95	—	7.52	6.00	4	0.75	—	7.99	0.98	6.69	6.69	3.03	12.79	6.69	6.10
4	100	3.94	—	9.02	7.50	8	0.75	—	9.02	1.06	7.68	7.68	4.02	14.57	8.15	6.42
5	125	4.92	4.33	10.00	8.50	8	0.87	—	10.24	1.06	9.25	9.25	4.41	16.03	8.94	7.09
6	150	5.91	5.12	10.98	9.51	8	0.87	—	10.51	1.06	10.63	10.63	5.20	17.52	10.35	7.17
8	200	7.72	6.61	13.50	11.75	6	0.87	2-W ³ / ₄	11.50	1.10	12.20	12.20	6.89	22.72	9.45	13.27

GATE VALVE (Rising Stem) 40mm - 200mm(1½ inch - 8inch)

FEATURES

·Externally threaded stem and straight flow channel prevent foreign matter deposits and restrictions through.

- 40mm(1½inch) – 150mm(6inch)
- 65mm(2½inch), 125mm(5inch)
- 200mm(8inch)

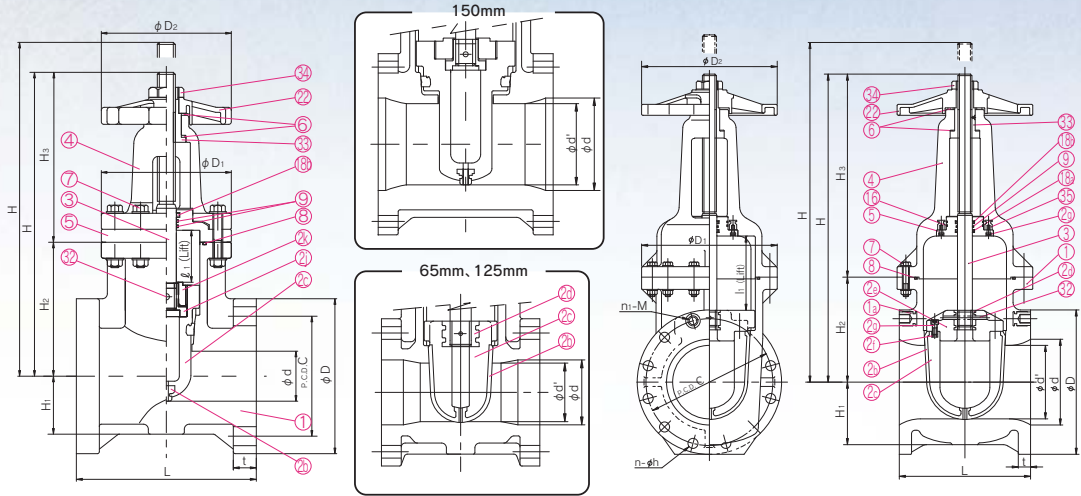

PARTS & MATERIALS

No.	DESCRIPTION	Pcs.	MATERIAL	No.	DESCRIPTION	Pcs.	MATERIAL	No.	DESCRIPTION	Pcs.	MATERIAL
①	BODY	1	HI-PVC	⑭	FEMALE SCREW HOLDER	1	HI-PVC, PVC	⑳	DUST SEAL(A)	1	EPDM, Others
⑫	INSERTED METAL OF BODY	4	COPPER ALLOY(C3604)	⑮	STEM	1	STAINLESS STEEL304	㉑	DUST SEAL(B)	1	NBR
⑬	SEAT	1	SBR, NBR	⑯	BONNET(A)	1	HI-PVC	㉒	HAND WHEEL	1	PP
⑰	GATE(A)	1	HI-PVC, C-PVC	⑳	BONNET(B)	1	HI-PVC, PP	㉓	PIN(A)	1	STAINLESS STEEL304
⑱	INSERTED METAL OF GATE(A)	1	BC6	㉁	THRUST RING	2	PP	㉔	SLEEVE	1	COPPER ALLOY(C3604), BC6
㉂	GATE(B)	1	HI-PVC	㉂	BOLT·NUT	—	STAINLESS STEEL304	㉕	NUT	1	COPPER ALLOY(C3604), BC6
㉃	INSERTED METAL OF GATE(B)	4	COPPER ALLOY(C3604)	㉃	O-RING(B)	1	EPDM, Others	㉖	INSERTED METAL OF BONNET	4	COPPER ALLOY(C3604)
㉄	BOLT(A)	4	STAINLESS STEEL304	㉄	O-RING(C)	2·1	EPDM, Others				
㉅	FEMALE SCREW METAL	1	COPPER ALLOY(C3604)	㉅	O-RING(D)	2	EPDM, Others				

DIMENSIONS TABLE

Nominal Size		JIS 10K														Unit:mm
mm	inch	d	d ₁	D	C	n	h	n ₁ -M	L	t	D ₁	D ₂	ℓ	H	H ₁	H ₂
40	1½	40	—	140	105	4	19	—	165	22	120	120	42	295	107	253
50	2	50	—	155	120	4	19	—	180	23	130	130	52	343	134	291
65	2½	65	—	175	140	4	19	—	190	24	155	155	67	407	152	340
80	3	75	—	185	150	8	19	—	200	25	170	170	77	450	170	373
100	4	100	—	210	175	8	19	—	230	27	195	195	102	564	207	462
125	5	125	110	250	210	8	23	—	260	27	235	235	112	593	227	481
150	6	150	130	280	240	8	23	—	270	28	270	270	132	690	263	558
200	8	196	168	330	290	10	23	2-M20	290	28	310	310	175	877	240	702

Nominal Size		DIN PN10														Unit:mm
mm	inch	d	d ₁	D	C	n	h	n ₁ -M	L	t	D ₁	D ₂	ℓ	H	H ₁	H ₂
40	1½	40	—	150	110	4	18	—	165	22	120	120	42	295	107	253
50	2	50	—	165	125	4	18	—	180	23	130	130	52	343	134	291
65	2½	65	—	185	145	4	18	—	190	24	155	155	67	407	152	340
80	3	75	—	200	160	8	18	—	200	25	170	170	77	450	170	373
100	4	100	—	200	180	8	18	—	230	27	195	195	102	564	207	462
125	5	125	110	250	210	8	18	—	260	27	235	235	112	593	227	481
150	6	150	130	285	240	8	23	—	270	28	270	270	132	690	263	558
200	8	196	168	340	295	6	23	2-M20	290	28	310	310	175	877	240	702

Nominal Size		ANSI Class 150														Unit:inch
inch	mm	d	d ₁	D	C	n	h	n ₁ -M	L	t	D ₁	D ₂	ℓ	H	H ₁	H ₂
1½	40	1.57	—	5.00	3.88	4	0.63	—	6.50	0.87	4.72	4.72	1.65	11.61	4.21	9.96
2	50	1.97	—	5.98	4.47	4	0.75	—	7.01	0.91	5.12	5.12	2.05	13.50	5.28	11.46
2½	65	2.56	—	7.01	5.49	4	0.75	—	7.48	0.94	6.10	6.10	2.64	16.02	5.98	13.39
3	80	2.95	—	7.52	6.00	4	0.75	—	7.99	0.98	6.69	6.69	3.03	17.72	6.69	14.69
4	100	3.94	—	9.02	7.50	8	0.75	—	9.02	1.06	7.68	7.68	4.02	22.20	8.15	18.19
5	125	4.92	4.33	10.00	8.50	8	0.87	—	10.24	1.06	9.25	9.25	4.41	23.35	8.94	18.94
6	150	5.91	5.12	10.98	9.51	8	0.87	—	10.51	1.06	10.63	10.63	5.20	27.17	10.35	21.97
8	200	7.72	6.61	13.50	11.75	6	0.87	2-W¾	11.50	1.10	12.20	12.20	6.89	34.53	9.45	27.64